

DIMENSIONS (SEE TABLE BELOW)

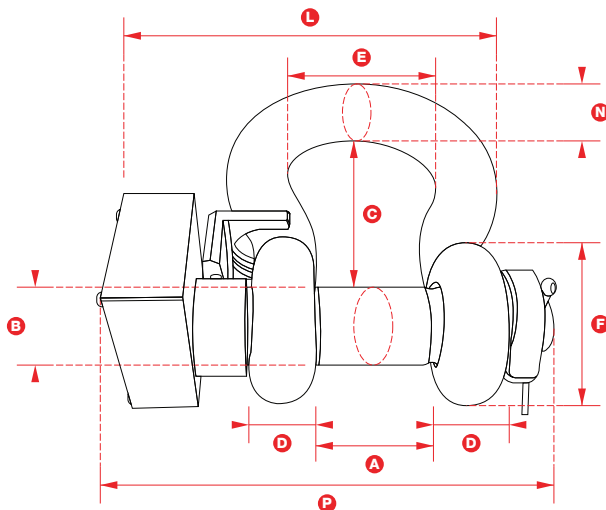

Simple to install wireless version bow shackle loadcell range from 1-400 tonne capacity.  
 Constructed from high tensile carbon steel.  
 Sealed to IP65 standards.  
 Proof tested to 150% of normal rated load.  
 Supplied with our standard Radiolink handheld display for use up to 100 metres.

PRICES AND SPECS [mm]

Part Number	WLS1T	WLS3.25T	WLS6.5T	WLS12T	WLS17T	WLS25T	WLS55T	WLS85T	WLS120T	WLS200T	WLS300T	WLS400T
Capacity	1t	3.25t	6.5t	12t	17t	25t	55t	85t	120t	200t	300t	400t
Resolution	0.001t	0.005t	0.005t	0.01t	0.02t	0.02t	0.05t	0.05t	0.1t	0.2t	0.5t	0.5t
Weight	2kg	2.8kg	3.2kg	8kg	12kg	18kg	25kg	45kg	85kg	215kg	364kg	520kg
Protection	IP65											
Safety Factor	300% of rated load											
Op Temp	-20 - 70c											
Accuracy	±1%											
Dimension A	16.8	26.9	36.6	51.5	60.5	73	82.5	105	127	184	213	210
Dimension B	11.2	19.1	25.4	35.1	41.4	51	57	70	82.5	121	152	178
Dimension C	36.6	60.5	84	119	146	178	197	267	330	397	495	572
Dimension D	9.65	16	22.4	31.8	38.1	44.5	51	66.5	76	95.5	121	165
Dimension E	26.2	42.9	58	82.5	98.5	127	164	184	200	279	330	330
Dimension F	23.1	38.1	53	76	92	106	122	145	165	267	305	356
Dimension H	63	106	148	210	254	313	348	453	546	743	895	1022
Dimension L	74.2	103.5	131	175	204	254	282	356	394	562	664	689
Dimension N	9.65	17.5	24.6	35.1	41.1	57	61	79	92	152	172	184
Dimension P	55	89.5	120	165	196	230	264	344	419	521	618	710

### Wireless Shackle Loadcell Accessories

Part Number	T24-SO	T24-PR1	T24-SOSD	T24-A01i
Description	Base Station with RS232	Wireless tally roll printer	125mm LED display wireless	Base Station with analogue output