

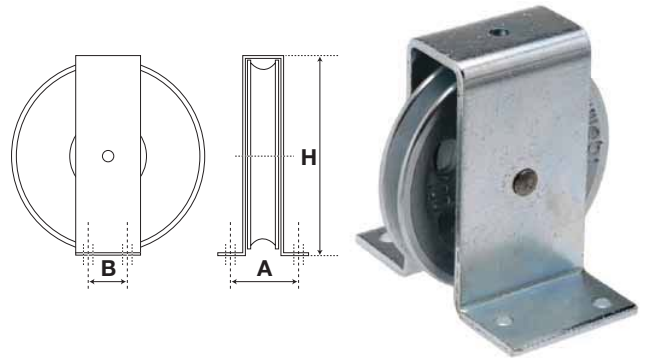

ETT-160 PULLEY COMPLETE WITH BRACKET - FOR WIRE ROPE

Material - galvanized cast iron pulley with pressed steel bracket

Product code	ETT - 160-60	ETT - 160-80	ETT - 160-100	ETT - 160-120
Diameter of pulley (mm)	60	80	100	120
Groove for wire cable Ø (mm)	3	4	4	5
Load Capacity (kg)	100	200	300	400
A (mm)	46	60	78*	70
B (mm)	20	24	42	46
H (mm)	66	88	109	130
Mounting hole Ø (mm)	5	6	7	10
Weight per item	0,35	0,6	1,1	1,6



PULLEY TYPE TYPE 3 - WITH BRACKET

Simple design for use with manual or electric winches. Made from cast iron with bronze bush. Bearing bracket: designed so that when the cable is guided between the pulley and the bracket, the wire cable can not jump or become trapped when slack cable builds up.

Cable exit: can exit vertically downwards, even if roller bracket is upright.

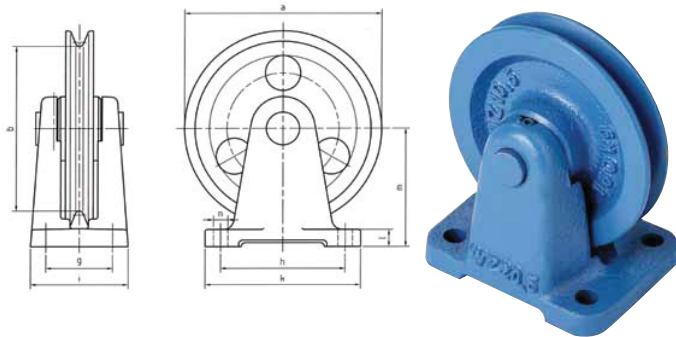

Max cable load	WZ 20.5	WZ 21	WZ 22	WZ 22.5	WZ 23	WZ 23.5	WZ 24	WZ 25
Manual Operation (kg)	150	250	500	750	1000	1500	2000	3200
Power [1] (kg)	75	125	250	375	500	750	1000	1600
Power [2] (kg)	100	180	320	500	630	1000	1250	2000
Cable Dia (mm)	3 - 4	4 - 5	5 - 6	6 - 8	8 - 10	10 - 12	12 - 14	14 - 16
Diameter (mm)	90	120	150	190	235	280	325	375
Weight	1.3	1.8	3.0	5.7	10.0	15.0	24.0	46

DIMENSIONS (mm)

Dimensions	WZ 20.5	WZ 21	WZ 22	WZ 22.5	WZ 23	WZ 23.5	WZ 24	WZ 25
aø	90	120	150	190	235	280	325	375
bø	72	100	125	160	200	240	280	320
g	44	50	55	65	70	80	95	95
h	62	70	88	120	150	180	212	240
i	66	74	82	95	108	120	143	185
k	84	92	115	150	187	220	260	300
l	10	13	15	17	20	22	25	22
m	57	75	92	115	138	164	190	212
nø	9	11.5	11.5	14	18	18	23	26