



The original electronic force measurement device with integral display.

In production since 1979, this is the latest version of this world renowned product.

All LLP's have push button control for: tare, units (kg, lbs, kN & tonnes), peak hold, pre set tare, audible setpoint alarm and overload counter.

Remote output is fitted as standard allowing connection to our range of accessories.

All models are supplied with carry/storage case.

DIMENSIONS (SEE TABLE BELOW)

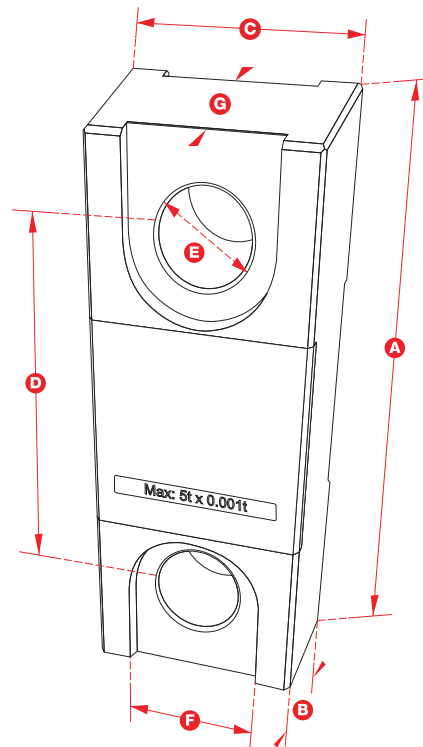

Part Number	LLP250KG	LLP500KG	LLP1T	LLP2T5	LLP5T	LLP12T	LLP25T	LLP50T	LLP100T	LLP200T	LLP250T
Capacity	250kg	500kg	1000kg	2.5t	5t	12t	25t	50t	100t	200t	250t
Resolution	0.05kg	0.2kg	0.5kg	0.001t	0.001t	0.002t	0.005t	0.01t	0.05t	0.1t	0.1t
Units	t, kg, kN, lbs										
Weight	1.5kg	1.5kg	1.5kg	1.5kg	2.2kg	3.5kg	5.2kg	10.9kg	37kg	80kg	80kg
Safety Factor	50:1	25:1	12:1	5:1	5:1	5:1	5:1	5:1	4:1	5:1	4:1
Battery Type	9v PP3										
Battery Life	80 hours continuous										
Display Type	25mm LCD										
Op Temp	-10 to 50c										
Accuracy	± 0.3% of applied load										
Protection	IP65										
Dimension A	204	204	204	204	249	305	340	424	608	690	690
Dimension B	43	43	43	43	43	47	60	75	99	150	150
Dimension C	101	101	101	101	101	101	110	163	255	305	305
Dimension D	146	146	146	146	165	193	215	230	320	350	350
Dimension E	24.5	24.5	24.5	24.5	38	47.5	55	76	108	125	125
Dimension F	47.5	47.5	47.5	47.5	66						
Dimension G	19	19	19	19	32						
Crosby Shackle	G210	G210	G210	G210	G210	G210	G210	G2140	G2140	G2140	G2140

LOADLINK PLUS