

Product Guide Sheet

Crane Slung Universal Drum Rotator

Our Universal Drum Rotator offers the ideal solution to the handling of a mixed variety of drums. In order to pick up a drum, set the girdle to the horizontal position, and position the girdle so as the girdle is within the rolling hoops if the drum is steel. Once the drum is in position it can be further secured by lowering the securing tie onto the drums top face. Once the drum is secured lifting and pouring can begin.

Minimum Drum Height – 780mm

Maximum Drum Height – 1000mm

Our Universal Drum Rotators will handle all types of drums, be it 110 or 210 litre sizes, plastic, steel or fibre. The drum platform provided ensures flexible sided drums do not slip during the rotation cycle. The attachment can be used on a fork truck or overhead crane.



Model Ref.	Capacity	No. Of Drums	Drum Types	Type of Op.	"A" Load Centre	"B" Fork Spread	"C" Fork Width	"D" Fork Thickness
DTRU-3	360kgs	1	1,2,3,4	Crank Handle	784mm	682mm	140mm	60mm
DTRU-4	360kgs	1	1,2,3,4	Loop Chain	784mm	682mm	140mm	60mm



Model Ref.	Weight	C of G
DTRU-3	100kgs	50mm
DTRU-4	104kgs	50mm

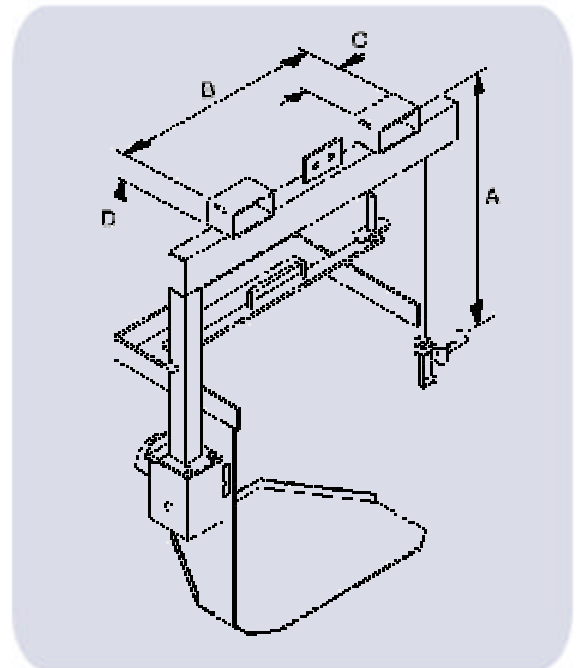

Ordering Information

Truck Capacity

Fork Width/Thickness

Drum Weight

Drum Type

Max Fork Spread

Drum Diameter

