

# Fully Stainless Roll Forward Skip

*Our best selling tipping skip. This skip can be used for a wide variety of applications and therefore makes it a popular choice for waste handling. Designed to be placed in production areas, Roll Forward skips keep working areas clear and allow safe and speedy removal of scrap or rubbish to the appropriate waste receptacle. All CONTACT skips have unique twin locks and simple to operate release mechanism, all skips also come with a retaining security chain for fastening to the truck.*

CONTACT Roll Forward Skips come with the benefits of having a full length release handle accessible from either side; this eliminates the need to lean

dangerously over the skip to activate it. This also means the skip can be tipped if positioned alongside a wall. Drilled castor plates allow for retro-fitment if required



Model Ref:	Volume	Capacity	A (mm)	B (mm)	C (mm)	D (mm)	E (mm)	F (mm)
RFS 25L-SS	0.25M <sup>3</sup>	1000KG	1148	794	678	1025	890	547
RFS 40L-SS	0.40M <sup>3</sup>	1000KG	1410	794	781	1197	890	547
RFS 80L-SS	0.80M <sup>3</sup>	1000KG	1480	1300	834	1325	890	600
RFS 120L-SS	1.2M <sup>3</sup>	1250KG	1710	1300	985	1540	890	750
RFS 160L-SS	1.6M <sup>3</sup>	1500KG	1710	1700	985	1540	890	750
RFS 200L-SS	2.0M <sup>3</sup>	1500KG	1710	2130	985	1540	890	750

Max Fork Size 150 x 65mm

Model Ref:	Weight	C of G (Min)	C of G (Max)	Load Centre
RFS 25L-SS	119	818	595	573
RFS 40L-SS	133	899	679	679
RFS 80L-SS	173	1042	735	735
RFS 120L-SS	206	1145	835	835
RFS 160L-SS	228	1178	835	835
RFS 200L-SS	256	1181	835	835

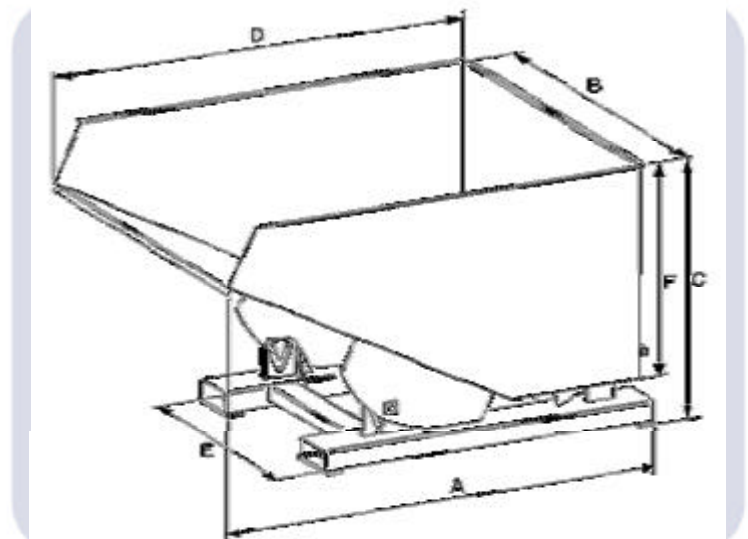

## Ordering Information

Product Handled?

Fork Width & Thickness?

Fork Spread?

Truck Capacity?

Type Of Working Environment?

## Optional Extras

C – Standard Castors

BC – Braked Castors

CIC – Cast Iron Castors

CIBC – Cast Iron Braked Castors

LL – Lifting Lugs

F – Fork Clamps

D – Drain Tap

AR- Auto Retention